

“Permanent Excavation Support in Urban Areas Using Cutter Soil Mixing Technology: Elliott Avenue Case History, Seattle, Washington”

Roberto A. Lopez, Ground Improvement Division, Malcolm Drilling Co., 3524 Breakwater Avenue Suite 108, Hayward, California

Andy Majewski, Malcolm Drilling Co., 8701 South 192nd Street, Kent, Washington

Terry Harvey, Ground Improvement Division, Malcolm Drilling Co., 3524 Breakwater Avenue Suite 108, Hayward, California

To Be Presented at:

International Foundation Congress and Equipment Expo ‘09

Orlando, Florida, March 15 – 19, 2009

**ADSC – International Association of Foundation Drilling
Geo-Institute of ASCE**

PDCA- Pile Driving Contractors Association

Permanent Excavation Support in Urban Areas Using Cutter Soil Mixing Technology: Elliott Avenue Case History, Seattle, Washington

Roberto A. Lopez¹, M. ASCE, P.E., Andy Majewski², and Terry Harvey³

¹Manager, Ground Improvement Division, Malcolm Drilling Company, Inc., 3524 Breakwater Avenue, Suite 108, Hayward, California 94545; rlopez@malcolmdrilling.com

²Project Engineer, Seattle District, Malcolm Drilling Company, Inc., 8701 South 192nd Street, Kent, Washington 98031; amajewski@malcolmdrilling.com

³Construction Manager, Ground Improvement Division, Malcolm Drilling Company, Inc., 3524 Breakwater Avenue, Suite 108, Hayward, California 94545; tharvey@malcolmdrilling.com

ABSTRACT

In one of the first applications of Cutter Soil Mixing (CSM) technology in the United States, a 12 to 17.4 m (40 to 57 ft) permanent deep soil mixed wall was constructed to enable the excavation for an office building near downtown Seattle in difficult soil conditions with a high water table.

Unlike conventional slurry walls and diaphragm walls that utilize concrete, soil mixing relies on mixing the soils in situ with a cement and bentonite slurry to create a soil-cement wall. Cutter Soil Mixing technology utilizes two sets of vertically mounted cutting wheels rotating about a horizontal axis to produce rectangular panels of treated soil. By overlapping the soil mix panels, a continuous rectangular wall is constructed, as opposed to circular columns created with conventional single-axis or multiple axes deep soil mixing systems.

The Elliott Avenue project located just north of downtown Seattle at the base of Queen Anne Hill required permanent excavation support to depths of up to 17.4 m (57 ft) in mixed soil conditions consisting of loose sands and gravels, underlain by stiff plastic clays and very dense glacial till. Because the project is located on the water front, the groundwater table at the site was found at a depth of 0.6 m (2 ft) from construction grade. It was thus necessary to support the saturated loose sands and gravels with a robust earth retaining system. Cutter Soil Mixing (CSM) was selected as the method of choice for several reasons, namely: price and schedule relative to a concrete secant pile wall; the ability of CSM to construct a permanent, high quality soil-cement wall in the dense gravels and stiff plastic clays; the capacity of the cutter mixing tool to key into the glacial till; and, the ability of CSM to produce a soil-cement material with a minimum strength of 1.38 mPa (200 psi) and a maximum permeability of 5×10^{-6} cm/sec.

BACKGROUND AND GEOTECHNICAL CONDITIONS

The area where the new Elliot Avenue building will be constructed is adjacent to Elliot Bay (part of Puget Sound) and was at one time the old Elliot Bay shoreline. Over the years the site has been filled so that the current shoreline is now located 90 to 120 m (300 to 400 ft) to the west of the project site (Kleinfelder 2007). As such, parts of an old buried sea wall, rip rap, timber piles and other obstructions were anticipated, and actually encountered, during construction of this project.

Soil conditions consisted of 3 to 4.5 m (10 to 15 ft) of loose sandy fill with gravel, wood debris and concrete obstructions. Underlying the fill were the original beach deposits, 3 to 6 m (10 to 20 ft) in thickness, consisting of very loose to medium dense silt, silty sand, clean sands and gravels. Below the beach deposits lies a stiff to hard, glacially overconsolidated clay layer, with SPT blowcounts ranging from 20 to 30 blows per foot and moderate to high plasticity, with 25 to 40 Plasticity Indices. Underlying the clays lies a very dense glacial till layer of silty sands with gravel with SPT values consistently higher than 50. The water table was found at a depth of 0.6 to 1.2 m (2 to 4 ft) below ground surface. To compound the high water table and difficult drilling conditions, the groundwater at the site was found to be contaminated with hydrocarbons and chlorinated solvents.

DESIGN

It was important for the shoring system not only to guarantee the stability of the excavation, but to keep the excavation dry and limit pumping of contaminated groundwater. Not only would this have led to expensive handling of the pollutants, but excessive dewatering would have likely induced settlement to the adjacent streets and the active Burlington Northern railroad line immediately west of the site.

The original design called for a concrete secant pile wall. Malcolm Drilling Company had already successfully installed such a wall further south along Elliott Avenue. This design had utilized circular shafts drilled in an overlapping pattern, with wide flange beams installed every other shaft and tieback anchors for lateral loads.

Malcolm Drilling Company proposed a soil cement wall constructed with the Cutter Soil Mixing technique as a means to reduce cost and shorten schedule, while at the same time complying with the technical requirements of the project and keeping the overall permeability of the system low. This technique was executed using a CSM tool able to cut a 2.4 m (7.9 ft) by 0.6 m (2 ft) rectangular panel. The overlap between primary and secondary panels was 0.15 m (0.5 ft), resulting in an effective cutting

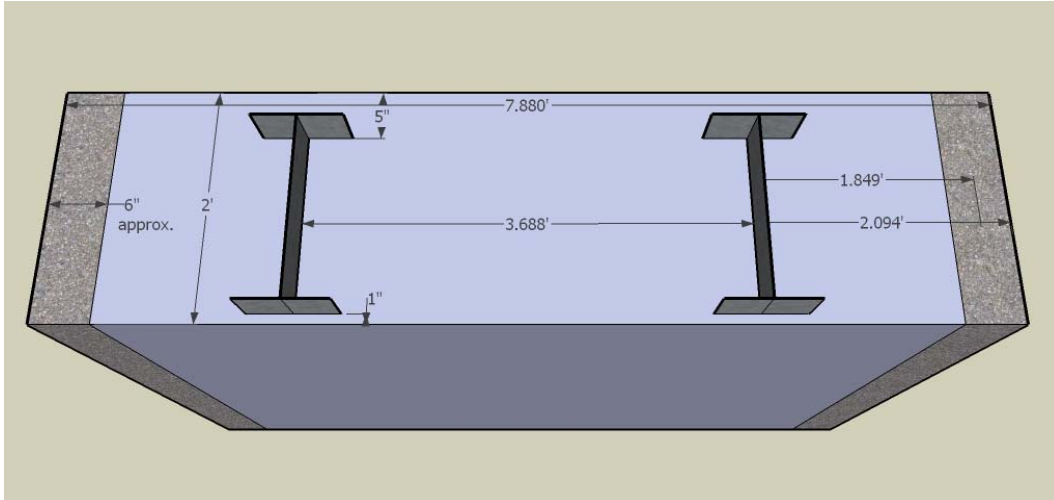

FIG. 1. Standard wall panel detail.

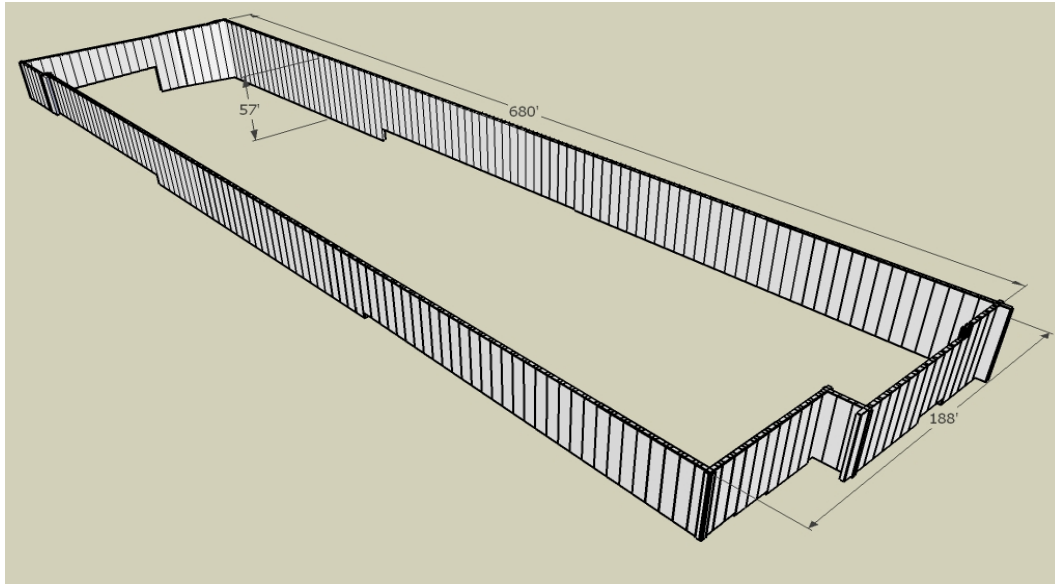

FIG. 2. Overall excavation rendering.

length of 2.25 m (7.4 ft). This in turn allowed for placing two wide flange beams in each panel, at 1.12m (3.7 ft) on center.

Depth of the panels was controlled by the need to key into the underlying clays and glacial till to minimize seepage into the cut, and by the need to cantilever portions of the wall. A minimum clay embedment depth of 2.3 m (7.5 ft) was selected to ensure low permeability of the wall. A single row of tiebacks was used on the northern, eastern and southern cuts for lateral loads, with design loads of 89 to 578 kN (20 to 130 kips), and total anchor lengths of 17 to 33 m (55 to 110 ft). All tiebacks were

placed above the water table to further reduce the risk of groundwater flow into the excavation. No tiebacks were used on the western wall due to the presence of the railroad tracks. See Figures 1 and 2 for wall panel details and a rendering of the excavation.

INSTALLATION PROCEDURE

Cutter Soil Mixing, CSM, is a new soil mixing technology developed in 2003 (Fiorotto et al 2005) and introduced in North America in 2005 (Wilson et al 2008). Cutter Soil Mixing was developed out of diaphragm wall technology and utilizes two sets of counter rotating vertical cutter wheels, as opposed to conventional soil mixing technology that employs one or multiple axes tools that rotate horizontally. The wheels cut the surrounding soil, while at the same time blend the injected cement-bentonite slurry with the in situ soil, producing a high quality soil-cement material. Figure 3 graphically depicts the CSM construction procedure.

There are several advantages to using a CSM system to construct a retaining wall over conventional soil mixing. For one thing, the mixing tool cuts vertical rectangular panels, which are more efficient for retaining wall geometry than tangent or secant columns, thus optimizing both mixing energy and binder. Secondly, the CSM system allows complete instrumentation inside the cutter gearbox support frame to read and control in real time the x, y and z coordinates of the cutting head. This inclinometer system, coupled with the advantage of a steerable tool, provides assurance of complete overlap between panels. Finally, the wheels are equipped with cutting teeth capable of drilling and mixing even in stiff ground and keying into bedrock.

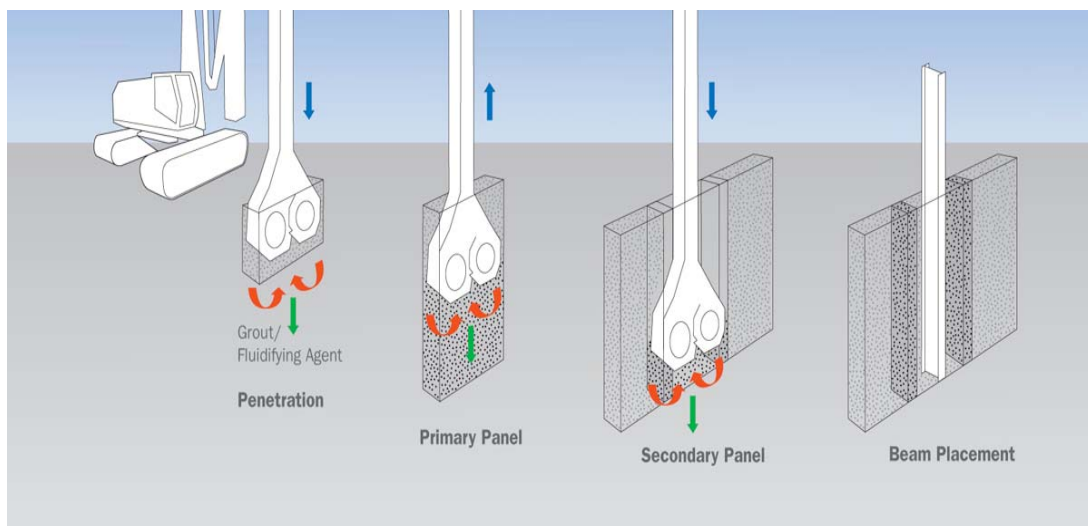

FIG. 3. Cutter Soil Mixing construction procedure.

QUALITY CONTROL / QUALITY ASSURANCE

The quality control program began with preproduction laboratory testing to identify a suitable grout slurry system. Tests panels were then constructed and wet grab samples were taken for both permeability and unconfined compressive strength testing. Coring was performed on selected panels with mixed results due to the consistent presence of gravels. Excavating of test panels was conducted, but only a small portion of these were visually inspected due to the high water table. Once production commenced, quality control was provided by real time measurements during the mixing process. These measurements were recorded and provided to the owner's representatives on a daily basis. Figure 4 shows a quality control log of a typical CSM panel.

The quality assurance system was provided by the owner's representatives. This consisted of wet grab samples taken from every other panel and tested for unconfined compressive strength. Approximately 25% of the samples were also tested for permeability using the ASTM falling head test. Figure 5 is the graphed result of the unconfined compressive strengths on grab samples. The average curves show the effect of early transport to the lab on the strength of soil mix samples.

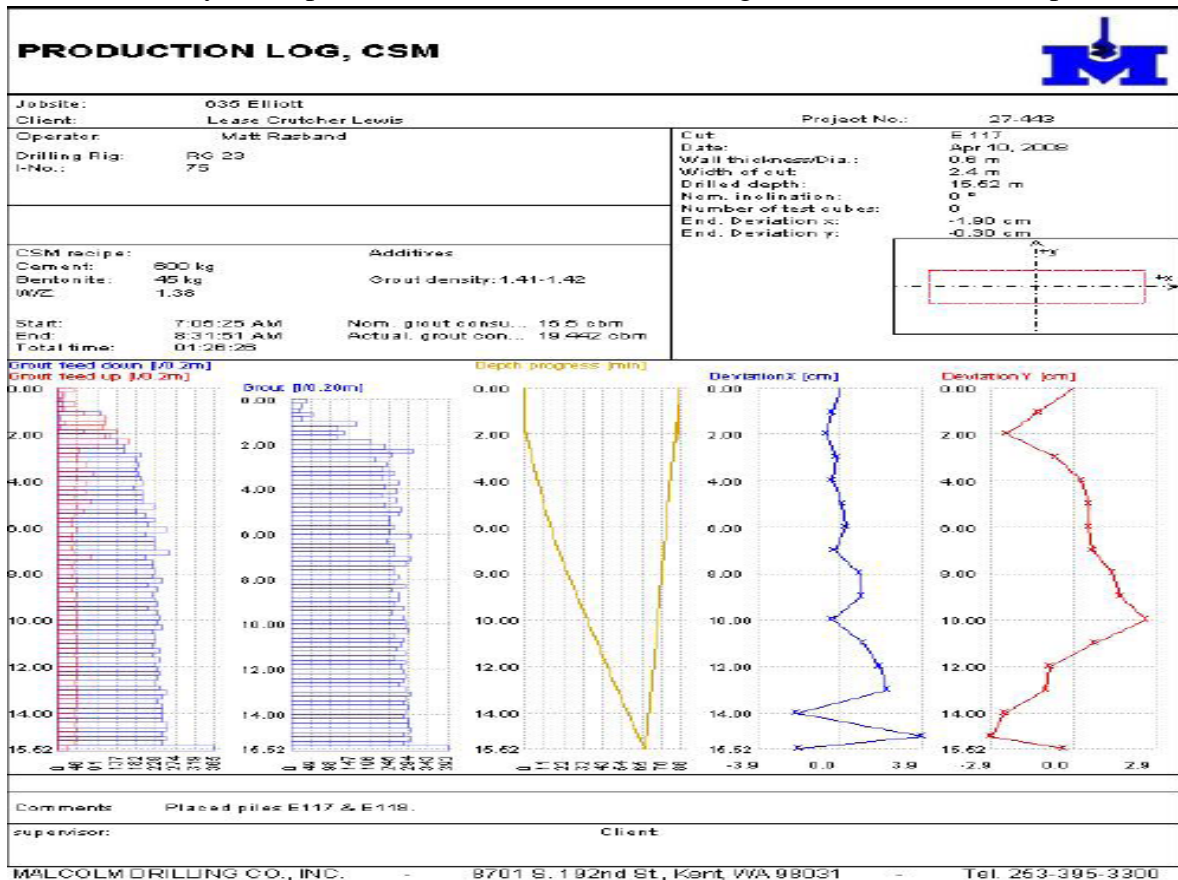

FIG. 4. Daily production report.

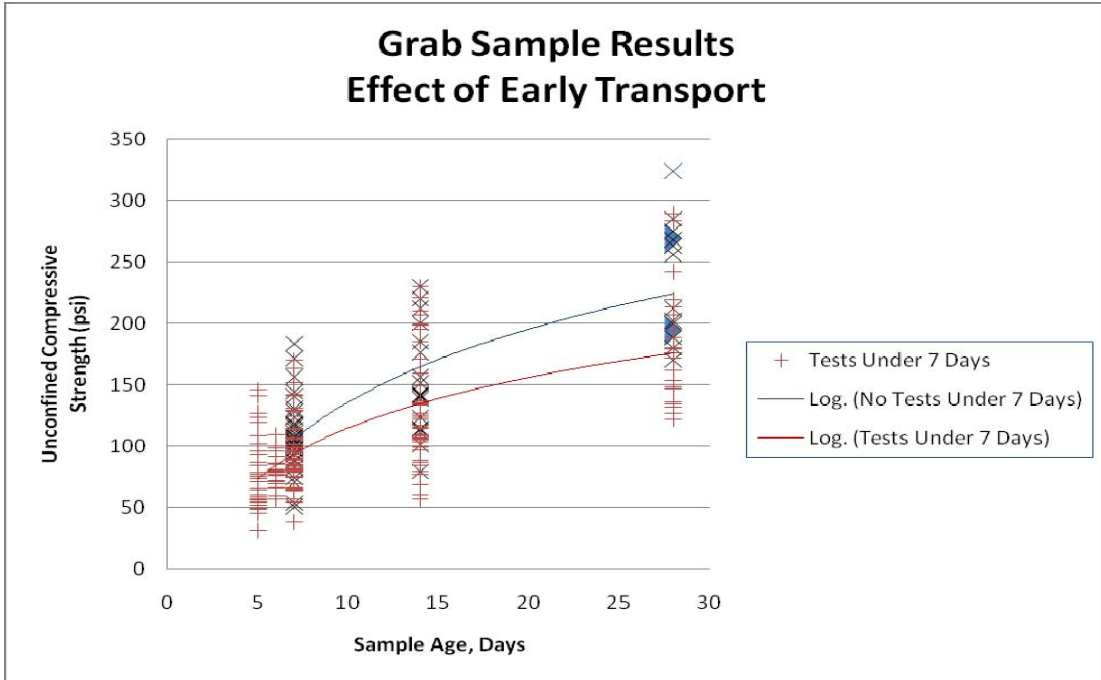

FIG. 5. Unconfined compressive strength results on grab samples.



FIG. 6. CSM rig in operation.



FIG. 7. Excavated soil mixed wall along Elliott Avenue.

Proper sample preparation techniques and transport are paramount to provide truly representative results.

Twenty eight permeability (falling head) tests were conducted, with results ranging from 1×10^{-6} to 8×10^{-8} , well within the permeability criteria of 1×10^{-5} . Measured flow into the excavation was on the order of 19 to 38 liters per minute (5 to 10 gpm), also satisfying the allotted amount of 151 liters per minute (40 gpm).

Figure 6 shows the Cutter Soil Mixing rig installing a panel along the east wall. Figure 7 shows the excavated east wall along Elliott Avenue.

CONCLUSIONS

Cutter Soil Mixing technology was successfully used to construct a permanent excavation support system in difficult soil conditions with a high water table, achieving soil cement unconfined compressive strengths in excess of 1.38 mPa (200 psi) and permeabilities below 5×10^{-6} cm/sec. This technology was successful in limiting the amount of dewatering in a site contaminated with hydrocarbons and chlorinated solvents and was able to support an urban excavation using 12 to 17.4 m (40 to 57 ft) high walls with only one row of tiebacks, placed intentionally above the water table to further limit ground water infiltration. The method proved to be fast and cost effective when compared to other earth retention systems and should be considered as a viable alternative in future deep excavations.

ACKNOWLEDGEMENTS

The authors are grateful to the following persons and organizations intimately involved with this project: Martin Selig Real Estate, Lease Crutcher Lewis, David Cotton and Robert Plum of Kleinfelder, Brian Robinson of KPFF, and John Kvinsland of Malcolm Drilling Company.

REFERENCES

- Fiorotto, R., Stotzer, E., Schopf, M., and Brunner, W. (2005). "Cutter Soil Mixing (C.S.M.) An Innovation in Soil Mixing for Creating Cut-Off and Retaining Walls." *Proceedings International Conference on Deep Mixing, Recent Advances and Best Practices*, Stockholm, Sweden.
- Kleinfelder, Inc. (2007). Preliminary Geotechnical Report 635 Elliott Project, Seattle, Washington. March 12, 2007
- Wilson, B., Scholte, J., and Atkinson, M. (2008). "Vancouver Island Conference Centre, Cutter Soil Mixer Transforms Site." *Deep Foundations Institute Magazine*, Summer 2008, pp 8 – 11.